



PowerPoint Jeopardy

Algebraic Reasoning	Geometry & Measurement	Problem Solving	Probability & Statistics	Potluck
<u>10</u>	<u>10</u>	<u>10</u>	<u>10</u>	<u>10</u>
<u>20</u>	<u>20</u>	<u>20</u>	<u>20</u>	<u>20</u>
<u>30</u>	<u>30</u>	<u>30</u>	<u>30</u>	<u>30</u>
<u>40</u>	<u>40</u>	<u>40</u>	<u>40</u>	<u>40</u>
<u>50</u>	<u>50</u>	<u>50</u>	<u>50</u>	<u>50</u>

$f(x) = 2x - 1$; find $f(-3)$



-7



Determine whether the ordered pairs of numbers below represent a function. Justify your answer.

$((2, -6), (7, 3), (-3, 4), (2, -3))$



Not a function; the domain value of 2 is paired to more than one range value (-6 and -3)



Write an equation that best describes the relationship between x and y in this table?

X	Y
-4	-11
-1	-2
2	7
5	16



$$y = 3x + 1$$



Fill in the table for the following equation:

x

$y = -2x^2 + 2$

-3

-2

-1

0

1

2

3



Fill in the table for the following equation:

<u>x</u>	<u>$y = -2x^2 + 2$</u>
-3	-16
-2	-6
-1	0
0	2
1	0
2	-6
3	-16



What is the solution to the following system of equations?

$$2x - y = 3$$

$$3x + 4y = -1$$



$(1, -1)$



A cardboard box is 60 inches long, 18 inches wide, and 24 inches high. What is the volume of the box in cubic feet?



15 ft³



The dimensions of two cubes are shown below.

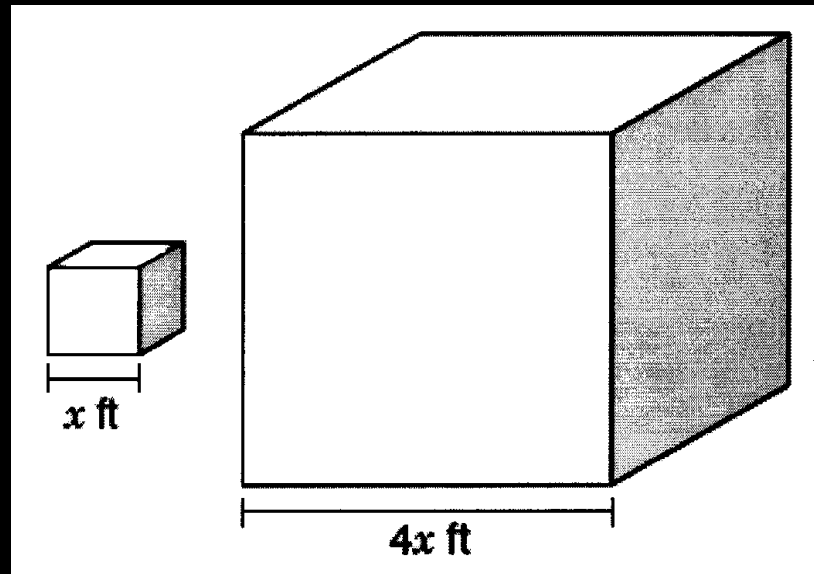

The volume of the smaller cube is 64 cubic feet. Find the volume of the larger cube.



4096 ft³



For small paving jobs, a contractor uses a roller pushed by a worker. To the nearest square inch, what is the area of pavement with which the surface of the roller will come into contact in one complete rotation?

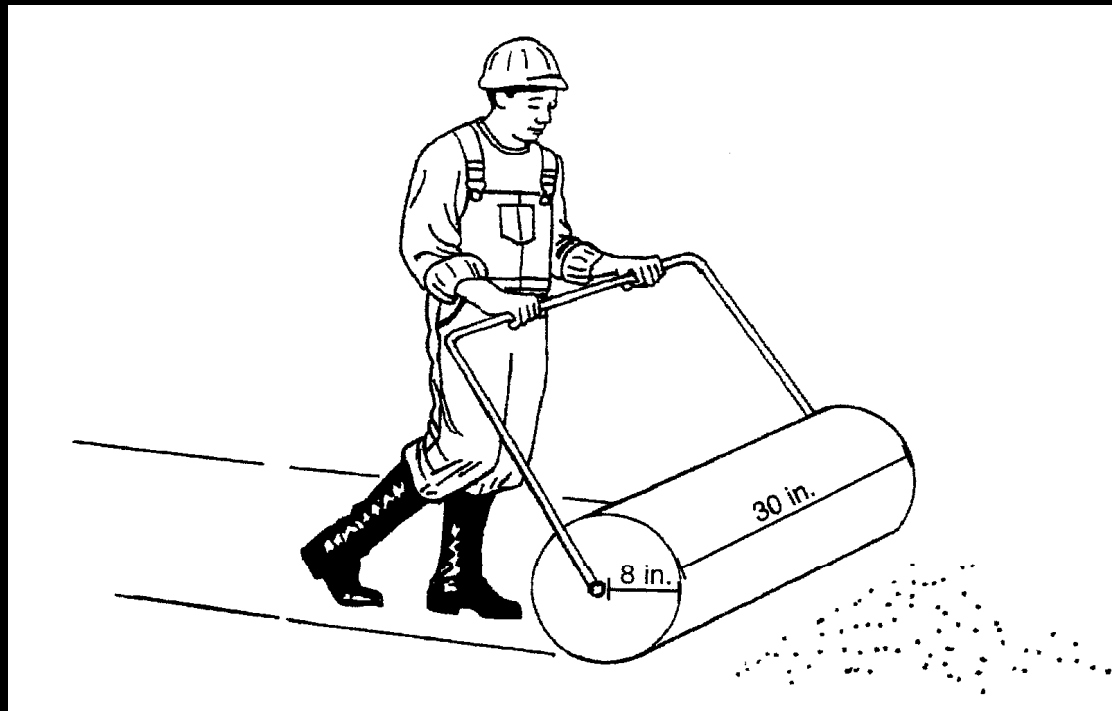

1507 in²



In a town, there is a small garden shaped like a triangle, as shown below. The side of the garden that faces Sixth Street is 80 feet in length. The side of the garden that faces Third Avenue is 30 feet in length.

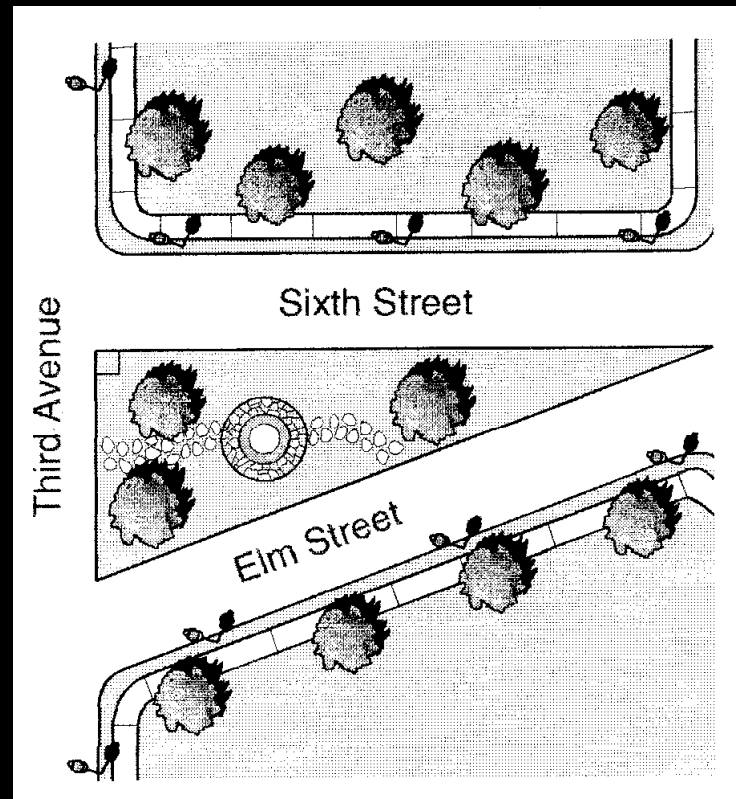

What is the approximate length of the side of the garden that faces Elm Street?

85 ft



Describe the effect on the area of a circle when the radius is doubled.



The area is increased 4 times.



Which problem can be solved using the equation below?

$$5x + 65 = 100$$

- A. Ali bought a pair of shoes for \$65 and 5 pairs of socks. If he paid a total of \$100, how much did the socks cost per pair?
- B. Greg lends a friend \$100 at a simple interest rate of 5% per year. After how many years will the interest on the loan equal \$65?
- C. It took John 5 hours to ride 65 miles during a bike race. If John rode at the same average speed, how long would it take him to ride 100 miles?
- D. At the beginning of the month, Meg had \$100 in her savings account. How much did she have left in her account after a withdrawal of \$65 and a deposit of \$5?



A. Ali bought a pair of shoes for \$65 and 5 pairs of socks. If he paid a total of \$100, how much did the socks cost per pair?



There are 4 children in the Carter family. Roger is $1 \frac{1}{4}$ times as tall as Charlie. John is 3 inches taller than Roger. Grace is 58 inches tall, and she is 2 inches taller than Charlie. How tall is John in feet and inches?



6ft 1in



The figure shows a rectangle inside a circle.

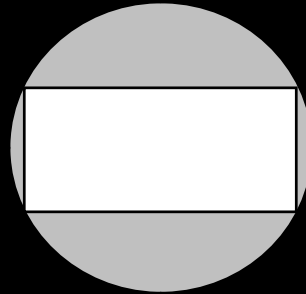

Which procedure should be used to find the area of the shaded region?

- A. Find the area of the circle and then subtract the area of the rectangle.
- B. Find the circumference of the circle and then subtract the perimeter of the rectangle.
- C. Find the circumference of the circle and then subtract the area of the rectangle.
- D. Find the area of the rectangle and then subtract the perimeter of the rectangle.



A. Find the area of the circle and then subtract the area of the rectangle.



The length of a rectangle is equal to triple the width. What system of equations can be used to find the dimensions of the rectangle if the perimeter is 85 centimeters?



$$l = 3w$$

$$2(l + w) = 85$$



The ratio of the diameter of a larger circle to the diameter of a smaller circle is $\frac{3}{2}$.
What number represents the ratio of the area of the larger circle to the area of the smaller circle?



9/4



Roseanne can read an average of 18 pages during a 30-minute reading period at school. At this rate, approximately how long will it take her to read a 380-page book?



10.55 hrs or 11 hrs



At Reyna High School 50% of the students eat lunch in the school cafeteria. In the same school 10% of the students participate in sports. What is the probability that a student selected at random eats in the school cafeteria and participates in sports? Express your answer in fraction form.



1/20



Last basketball season Ricky made 58% of the free throws he attempted. In the first game this season, Ricky went to the free-throw line 10 times. About how many free throws did Ricky make if his success rate from last season continued?



5.8 or 6



Luther entered his chili in the cook-off at the county fair. His chili was rated by five judges using a scale of 1–10, in which 1 was the lowest score and 10 the highest. His scores were 3, 3, 6, 7, and 8. Which measure of Luther's data would give his chili the highest final score?

- A. Mean
- B. Mode
- C. Median
- D. Range



(C) Median = 6



A clothing store surveyed 100 boys aged 12 to 16 about their preferred T-shirt colors. The results are shown in the table.

Color	Frequency
Purple	35
Orange	45
Green	15
Yellow	5

If the store uses only these data to order T-shirts, which conclusion best reflects the data collected?

- A. More than half of each order should be orange T-shirts.
- B. More than half of each order should be purple T-shirts and orange T-shirts.
- C. Only purple T-shirts and orange T-shirts should be ordered.
-  D. About a third of the order should be green T-shirts and yellow T-shirts.

B. More than half of each order should be purple T-shirts and orange T-shirts.



Vicki works as a salesclerk in a clothing store. She earns \$10 per hour plus a commission of 6% of her total sales. Write an equation that represents e , her total earnings when she works h hours and sells a total of d dollars in merchandise?



$$C = 10h + 0.06d$$



Monica collected data on the ages and heights of a random sample of sixth-, seventh, and eighth-grade students at her school. If she plots the data on a scatterplot, what relationship will she most likely see between age and height?



Positive Correlation



The figures below show a pattern of dark tiles and white tiles that can be described by a relationship between 2 variables.

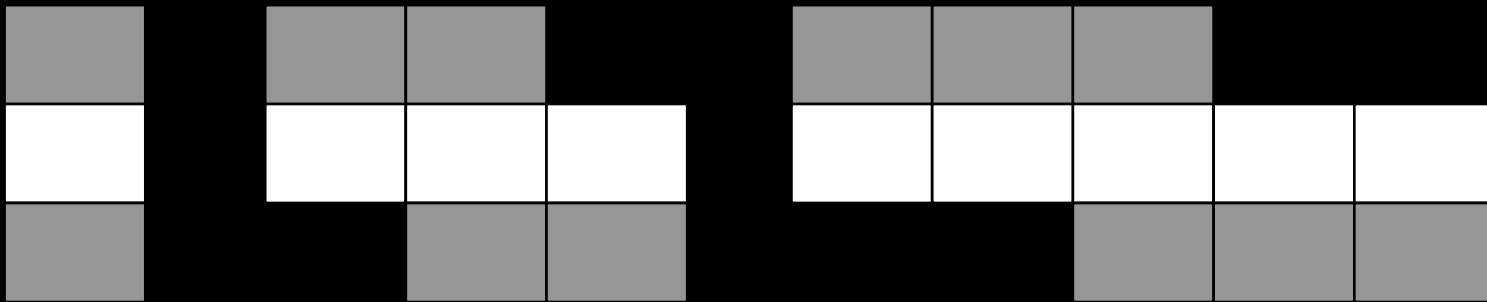

What rule relates d , the number of dark tiles, to w , the number of white tiles?



$$w = d - 1$$



Solve the equation $2a - 6 + 5a = 3a + 10$ for a



$$a = 4$$



Simplify the expression below:

$$(5n - 2)3n - (5n - 2)(n - 1)?$$



$$10n^2 + n - 2$$

